

May 1st 2021  
Volume 2, Issue 1

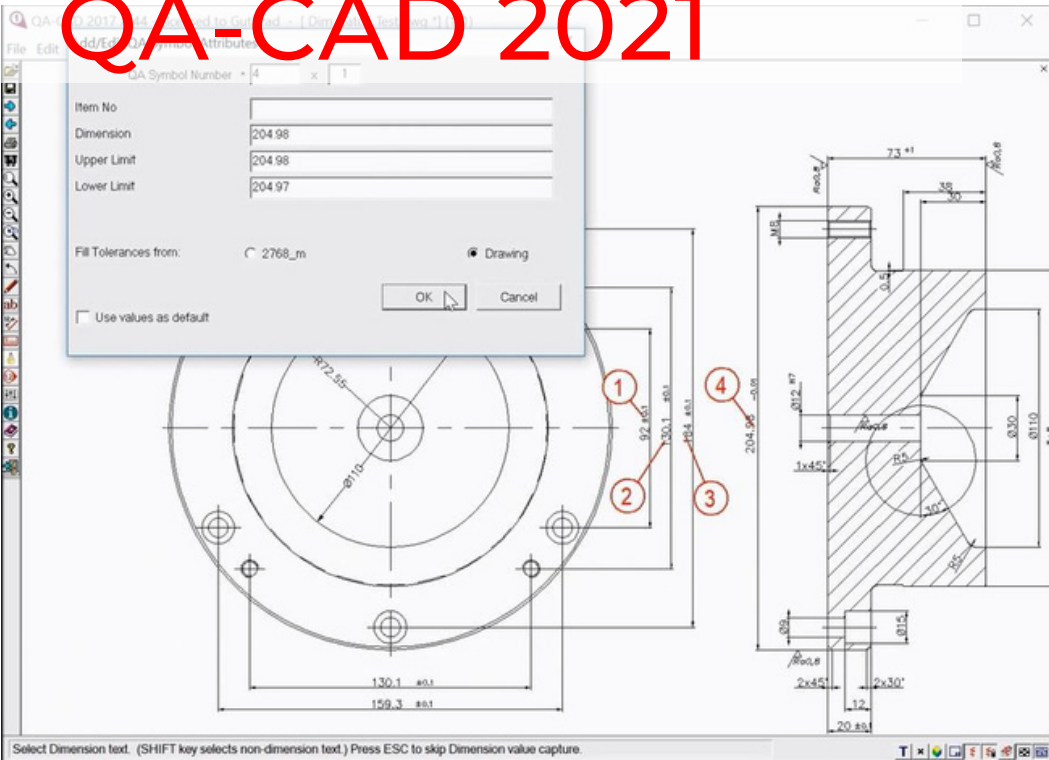

# QA-CAD 2021



## First Article Inspection Report Software

QA-CAD quickly minimizes the time to produce a First Article Inspection (AS9102, PPAP, etc.) and ballooned drawing by 30% to 80%. *The new automated ballooning feature is available for PDF, raster image (TIF, JPEG, GIF) and CAD files.* Of course, you can export data to not only AS9102 forms but also your customized report EXCEL file!

# Software Overview

QA-CAD enables you to quickly add balloons (bubbles), or QA stamps to identify dimensions, tolerances and GD&T on your drawing while reducing the chance of errors from manually inputting information.

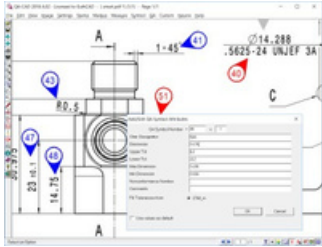

- **Export embedded data to EXCEL/CSV for AS9102/EN9102/SJAC9102, PPAP, ISO 13845 etc.**
- **Easy to draw balloons, execute auto ballooning and adjust balloons size, color and numbers**
  - **Capture dimensions, tolerances, notes and GD&T features control frames automatically**
  - **Export ballooned drawing to PDF or image**

QA-CAD is an essential tool in the quality assurance process. If you are still plotting drawings and adding numbered stamps and revisions by hand, then QA-CAD is for you! Save your valuable time and resources with our QA stamping software that overlays drawings with auto-numbered stamps and markup notes and corrections (text, sketches, boxes, lines, and arrows).

With just a press of a button the drawing, along with the revision stamps and markup notes/corrections, can be saved to a PDF and sent in an email. The source drawing remains untouched by the stamping and markup operations.

# Automated ballooning for PDF/CAD files.

1) With this new feature, you select multiple dimensions by drawing a rectangle first.

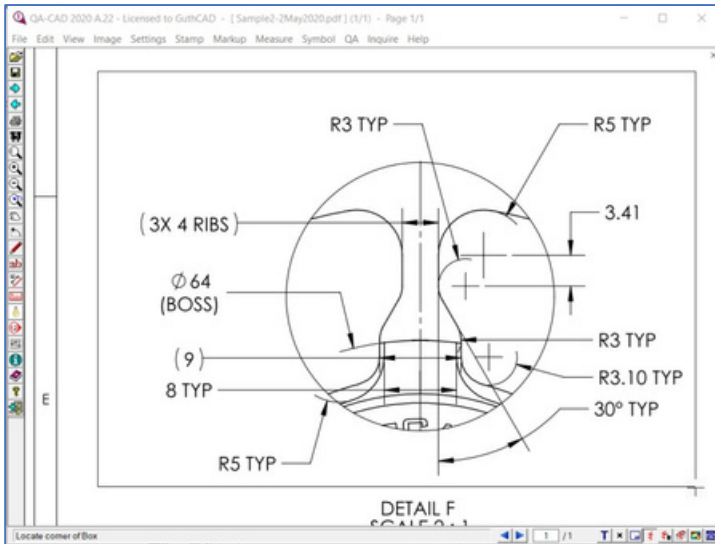

2) Then QA-CAD instantly draws automated balloons to all selected dimensions. Of course, QA-CAD extracts dimensions, tolerances, and notes at the same time. QA-CAD can balloon specific page areas or the entire page with just a few button operations.

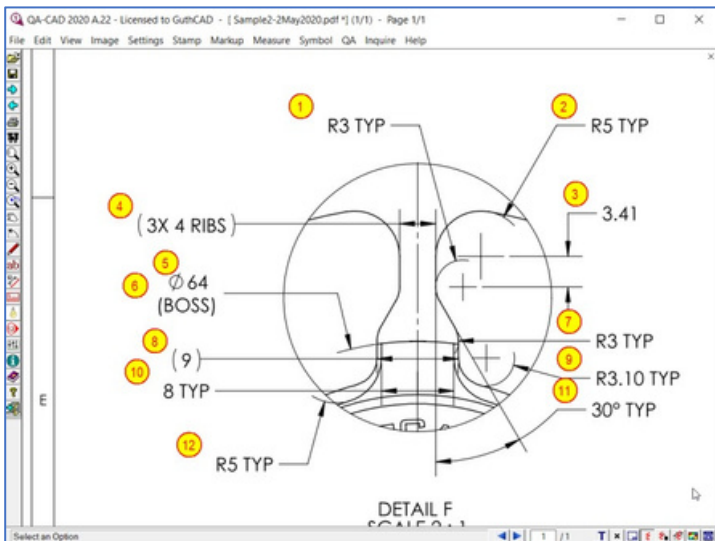

# QA-CAD screenshot images

Capture dimensions, tolerances, notes or GD&T features control frames directly from PDF, images or CAD drawing

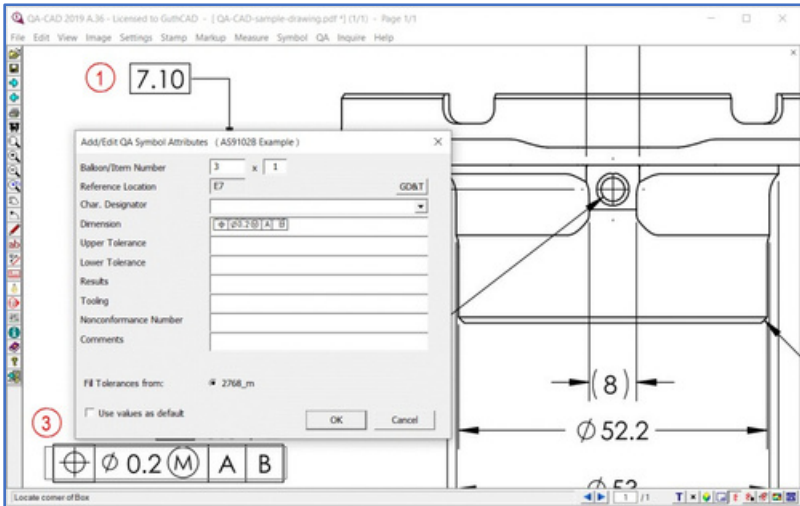

AS9102 Rev. B Form 3, which is exported from QA-CAD

QA-CAD-sample-drawing - AS9102B.xlsx - Excel

QA-CAD EXCEL EXAMPLE

File Home Insert Page Layout Formulas Data Review View Help Acrobat Tell me Share

E21

Sample AS9102B Form

FORM 3: CHARACTERISTIC ACCOUNTABILITY, VERIFICATION, AND COMPATIBILITY EVALUATION

1. Part Number		2. Part Name				3. Serial Number			
Characteristic Accountability				Inspection / Test Results					
5. Char No.	6. Reference Location	7. Characteristic Designator	8. Requirement	Upper Tolerance	Lower Tolerance	9. Results	10. Designed / Qualified Tooling	11. Nonconformance Number	14. Additional
1	Sheet 1, F7	Linear Dimension	7.1	0.2	-0.2				
2	Sheet 1, E7		0.4 THRU	0.1	-0.1				
3	Sheet 1, E7	True Position	$\phi(0.2 @) A B$						
4	Sheet 1, E6		0.522	0.3	-0.3				
5	Sheet 1, E6		$\phi 5.3$	0.3	-0.3				
6	Sheet 1, E6		0.66	0.3	-0.3				
7	Sheet 1, E6		1X 45°	0.1	-0.1				
8	Sheet 1, F5		0.75 X 30°	0.1	-0.1				
9	Sheet 1, F5	Flatness	$\sqrt{A} 0.02$						

Form1 Form2 Form3

+ 80%

You can choose an EXCEL template file to export your embedded data.

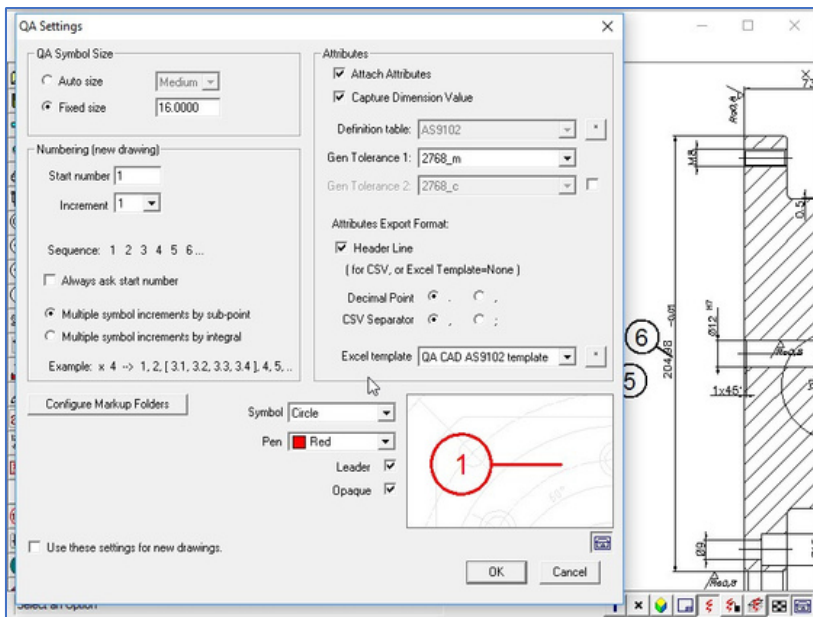

You can also customize EXCEL templates and their OUTPUT columns configurations.

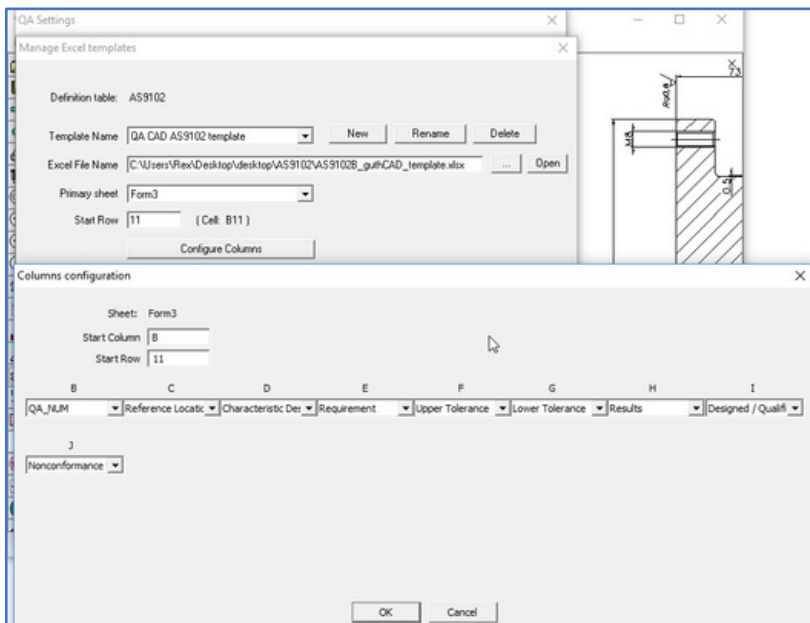

# Our Clients for QA-CAD

Over 1800 companies currently rely on our QA-CAD software including large companies such as:



SIEMENS

GE (General Electric)

BOSCH

Northrop Grumman

TOYOTA Industries

IHI Turbochargers

Thyssenkrupp

Alstom SA

Hanwha

Mitsubishi Electric

MAHLE

STIHL

MAGNA

DAIKIN

Continental

FOXCONN

Carl Zeiss

Infineon Technologies

And more..

"The software support was just stunning! The support staff resolved my CAD drawing problem within hours!"

Kris Wojcysz

TENIX MAINTENANCE  
SERVICES PTY LTD

"I am happy to tell you that we are content with the functionality of QA-CAD."  
Calina C.

GENERAL ELECTRIC

# Support Windows OS:

Windows 2003/2008/2012/Citrix/XP/XP64/Vista/Vist64/Win7/  
Wino7x64/Win8/Win8x64/Win10/Win10x64

# Software License Type:

## Standard License:

QA-CAD standard licenses are 'per user' licenses which permit installation to the same number of PCs as the number of users for the license.

## Network License:

Concurrent-User licenses may be installed on any number of PCs in a single network. The number of users permitted to use the software at the same time (concurrently) is restricted to the number of concurrent users specified in the License.

A Company License allows the software to be installed on any number of PCs or networks, for exclusive use within the corporate entity within a single country.

## What are 'Network' licenses, and how do they differ from standard licenses?

Network licensing allows multiple users to use the software, but is restricted to how many of those users may use the software at the same time (i.e. concurrently.)

Network licenses may only be installed to a single organization network (typically a single server) at a single physical location. Any number of users on the network may potentially have access to the software, however the number of such users that are permitted to use the software at the same time (concurrently) is restricted to the number specified in the license that was purchased.

Standard (or 'per user') licenses on the other hand count each desktop computer, or notebook/laptop computer, or workstation on the network, in the total count of users for the license.

# Software Support:

## **1 Year of Free Software Updates**

Updates to the latest version of the software are provided free for 12 months from the date of purchase.

## **1 Year Free Technical Support**

Free Email technical support is provided for 12 months from the date of purchase.

## **30 Day Money Back Guarantee**

If you are not completely satisfied with the software let us know within 30 days of purchase and we will refund your purchase price (you must agree to remove the software from your machines)



# Software Specifications:

---

<p><b>EXPORT EMBEDDED DATA TO EXCEL/CSV:</b></p> <ul style="list-style-type: none"><li>• Export embedded data to EXCEL forms for your First Article Inspection Report, AS9102, and PPAP</li><li>• Export embedded data to a spreadsheet (EXCEL/ CSV) for revision management or inspection</li><li>• Export ballooned drawing to PDF</li><li>• Export bills of characters to customizable EXCEL reports.</li></ul>	<p><b>BALLOON SIZE, COLOR, AND NUMBERS:</b></p> <ul style="list-style-type: none"><li>• Color changer - Choose from 20 different ballooning ink (stamping inks).</li><li>• Alter each stamp to any size.</li><li>• Rotate stamps in any direction.</li><li>• Add leaders to stamps.</li></ul>
<p><b>BALLOONS (BUBBLES) DRAWING FEATURE:</b></p> <ul style="list-style-type: none"><li>• You can choose to draw balloons (bubbles) or QA Stamps on AutoCAD / PDF drawing</li><li>• Overlay drawings with unlimited no. of balloons or QA stamps and Markup annotations.</li><li>• Field-based data or attributes may be embedded into balloons or QA stamps.</li></ul>	<p><b>CAPTURE DATA FROM PDF AND CAD DRAWING:</b></p> <ul style="list-style-type: none"><li>• Automatically pick up dimension, tolerance, GD&amp;T features control frames and notes from PDF, image files or AutoCAD drawings.</li><li>• Automated PDF drawing ballooning is available.</li></ul>
<p><b>SUPPORT MULTIPLE FORMATS:</b></p> <ul style="list-style-type: none"><li>• Vector (DWG, DXF, HPGL/2, DWF), pixel (TIFF, JPG, BMP) and PDF formats can be opened and stamped.</li><li>• All AutoCAD formats support including AutoCAD 20201.</li><li>• Save the drawing with bubbles and markup overlays to PDF, DWG, DXF, TIFF ...</li></ul>	<p><b>SAVE BALLOON EDITS:</b></p> <ul style="list-style-type: none"><li>• Save balloons (QA stamps) and markup annotations separate in the drawing (the original drawing file is untouched).</li></ul>
<p><b>AUTO-NUMBERED BALLOONS:</b></p> <ul style="list-style-type: none"><li>• Stamps are automatically numbered and easily configured.</li><li>• Alter numbering system of balloons (QA Stamps) anytime during the stamping process.</li></ul>	<p><b>INTEGRATION WITH YOUR EMAIL SOFTWARE:</b></p> <ul style="list-style-type: none"><li>• Send ballooned PDF by email with just the process of a button.</li></ul>

---

---

DEFINITION TABLE:

- Import and export your table definition file

FIELD ENTRY CONTROL:

- Option to configure field entry controls as a dropdown list of user defined values.

---

USER-DEFINED STAMP:

- User-defined Time / Date / 'Checked by' stamp.

AUTOMATIC TOLERANCE

INPUT:

- You can set up your own default linear/angular tolerance value with decimal places or ranges and insert tolerance based on dimension automatically.
  - You can select built-in industry tolerance standards (ISO, DIN, JIS, etc.) and insert tolerance based on tolerance automatically.
-

## About us

### IQM Solutions Pvt. Ltd.

Mailing Address:

C-521, I-Thum Building, Plot No A-40, Sector-62,

Noida-201301, Uttar Pradesh, INDIA

+91 9871860255

Email: [info@iqmsolutions.co.in](mailto:info@iqmsolutions.co.in)

<http://www.iqmsolutions.co.in/digiverse-auto-ballooning>